

NI PXI/PCI-5124 Specifications

12-Bit 200 MS/s Digitizer

This document lists the specifications for the NI PXI/PCI-5124 (NI 5124) high-speed digitizer. Unless otherwise noted, these specifications are valid for the following conditions:

- All filter settings
- All impedance selections
- Sample clock set to 200 MS/s using onboard clock

Typical values are representative of an average unit operating at room temperature. Specifications are subject to change without notice. For the most recent NI 5124 specifications, visit ni.com/manuals.

To access the NI 5124 documentation, including the *NI High-Speed Digitizers Getting Started Guide*, which contains functional descriptions of the NI 5124 signals, navigate to **Start»All Programs»National Instruments»NI-SCOPE»Documentation**.



Hot Surface If the NI 5124 has been in use, it may exceed safe handling temperatures and cause burns. Allow the NI 5124 to cool before removing it from the PXI chassis or PC. Refer to the [Environment](#) section for operating temperatures of this device.

Contents

Vertical.....	2
Analog Input (Channel 0 and Channel 1)	2
Horizontal.....	13
Sample Clock	13
Phase-Locked Loop (PLL) Reference Clock.....	16
CLK IN (Sample Clock and Reference Clock Input, Front Panel Connector)	17
CLK OUT (Sample Clock and Reference Clock Output, Front Panel Connector)	17
Trigger.....	17
Reference (Stop) Trigger	17
TRIG (External Trigger, Front Panel Connector).....	19

PFI 0 and PFI 1 (Programmable Function Interface, AUX Front Panel Connector)	20
TClk Specifications	21
Waveform Specifications	22
Calibration	23
Power	23
Software	24
Environment	25
NI PXI-5124	25
NI PCI-5124	26
Safety, Electromagnetic Compatibility, and CE Compliance	27
Safety	27
Electromagnetic Compatibility	27
CE Compliance	27
Environmental Management	28
Physical	28
Front Panel Connectors	28
Dimensions and Weight	29
Where to Go for Support	31

Vertical

Analog Input (Channel 0 and Channel 1)

Specification	Value		Comments
Number of Channels	Two (simultaneously sampled)		—
Connector	BNC		—
Impedance and Coupling			
Input Impedance	50 Ω \pm 2.0%	1 M Ω \pm 0.75% in parallel with a typical capacitance of 29 pF	Software selectable
Input Coupling	AC, DC, GND		AC coupling available on 1 M Ω only

Specification	Value				Comments
Voltage Levels					
Full Scale (FS) Input Range and Programmable Vertical Offset	50 Ω		1 M Ω		—
	Range (V _{pk-pk})	Vertical Offset Range (V)	Range (V _{pk-pk})	Vertical Offset Range (V)	
	0.2	± 0.1	0.2	± 0.1	
	0.4	± 0.2	0.4	± 0.2	
	1	± 0.5	1	± 0.5	
	2	± 1	2	± 1	
	4	± 2	4	± 2	
	10	0	10	± 5	
		20	0		
Maximum Input Overload	50 Ω		1 M Ω		—
	7 V _{rms} with Peaks ≤ 10 V		Peaks ≤ 42 V		
Accuracy					
Resolution	12 bits				—
DC Accuracy (Programmable Vertical Offset = 0 V)	Range (V _{pk-pk})	NI PXI-5124	NI PCI-5124		Within ± 5 °C of self-calibration temperature
	0.2 and 0.4	$\pm(0.65\%$ of Input + 1.3 mV)	$\pm(0.65\%$ of Input + 1.8 mV)		
	1 and 2	$\pm(0.65\%$ of Input + 1.5 mV)	$\pm(0.65\%$ of Input + 2.1 mV)		
	4, 10, and 20 (1 M Ω only)	$\pm(0.65\%$ of Input + 10.0 mV)	$\pm(0.65\%$ of Input + 10.0 mV)		
Programmable Vertical Offset Accuracy	$\pm 0.4\%$ of offset setting				Within ± 5 °C of self-calibration temperature

Specification	Value			Comments
DC Drift	Range (V_{pk-pk})	50 Ω and 1 M Ω		—
	0.2, 0.4, 1, and 2	$\pm(0.057\%$ of Input + 0.006% of FS + 100 μ V) per $^{\circ}$ C		
	4, 10, and 20 (1 M Ω only)	$\pm(0.057\%$ of Input + 0.006% of FS + 900 μ V) per $^{\circ}$ C		
AC Amplitude Accuracy	50 Ω		1 M Ω	Within $\pm 5^{\circ}$ C of self-calibration temperature
	± 0.06 dB ($\pm 0.7\%$) at 50 kHz		± 0.09 dB ($\pm 1.0\%$) at 50 kHz	
Crosstalk, Typical	≤ -85 dB at 10 MHz			CH 0 to/from CH 1, External Trigger to CH 0 or CH 1
Sparkle Code Rate, Typical	<300 ppt* with onboard clock or 200 MHz external clock <3 ppt* with 150 MHz external clock 0 with 100 MHz external clock			Results based on 2×10^{12} samples * ppt = parts per trillion (10^{12})
Bandwidth and Transient Response				
Bandwidth (-3 dB)	Range (V_{pk-pk})	50 Ω	1 M Ω	Filters off * 135 MHz above 40 $^{\circ}$ C
	All ranges except 0.2	150 MHz	145 MHz up to 40 $^{\circ}$ C*	
	0.2	85 MHz	75 MHz	
Rise/Fall Time, Typical	Range (V_{pk-pk})	50 Ω and 1 M Ω		Filters off
	All ranges except 0.2	2.4 ns		
	0.2	3.3 ns		
Bandwidth Limit Filters	Noise Filter		Antialias Filter	Only one filter can be enabled at any given time. The antialias filter is enabled by default.
	20 MHz, typical 2-pole Bessel filter		60 MHz, typical 4-pole elliptical filter	

Specification	Value			Comments
AC Coupling Cutoff (-3 dB)	12 Hz			AC coupling available on 1 M Ω only
Passband Flatness	Filter Settings	Range (V _{pk-pk})	50 Ω and 1 M Ω	Referenced to 50 kHz
	Filters Off	All ranges except 0.2	± 0.5 dB DC to 20 MHz ± 1.0 dB 20 MHz to 50 MHz ± 1.7 dB 50 MHz to 100 MHz	
		0.2	± 0.6 dB DC to 20 MHz ± 1.5 dB 20 MHz to 40 MHz	
	Antialias Filter On	All ranges	-1.0 dB to +2.0 dB DC to 55 MHz	

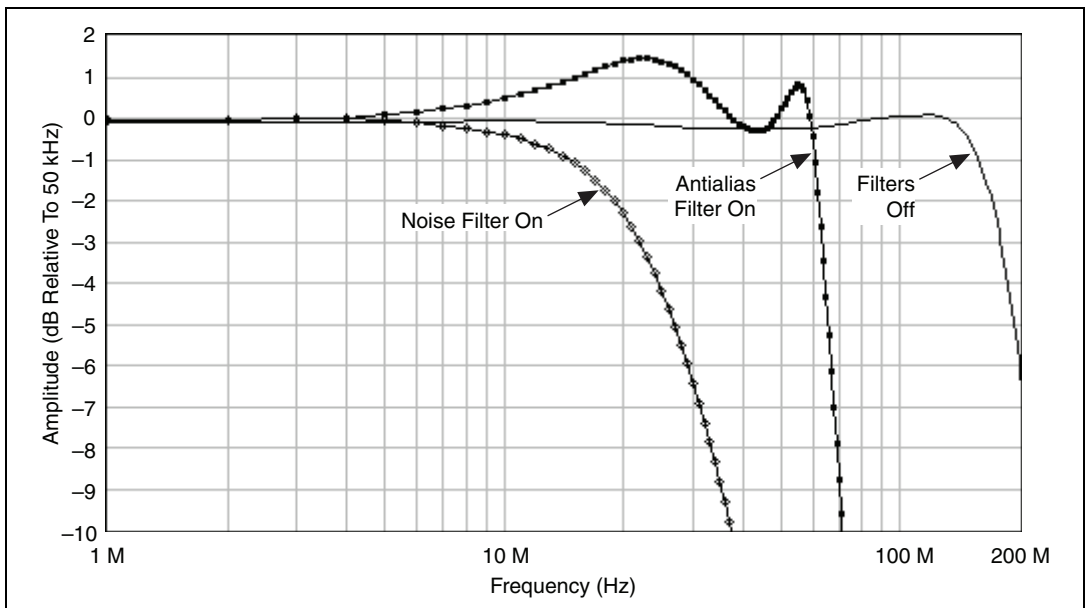

Figure 1. NI 5124 Frequency Response (Typical)

Specification	Value			Comments
Spectral Characteristics				
Spurious-Free Dynamic Range with Harmonics (SFDR) (Physical), Typical	Range (V_{pk-pk})	50 Ω	1 M Ω	Filters off or antialias filter on 10 MHz, -1 dBFS input signal Includes the 2nd through the 5th harmonics Measured from DC to 100 MHz on NI PXI-5124 Measured from 5 kHz to 100 MHz on NI PCI-5124
	0.2	75 dBc	70 dBc	
	0.4	75 dBc	70 dBc	
	1	72 dBc	70 dBc	
	2	72 dBc	70 dBc	
	4	65 dBc	67 dBc	
	10	65 dBc	60 dBc	
	20 (1 M Ω only)	—	60 dBc	
Total Harmonic Distortion (THD), Typical	Range (V_{pk-pk})	50 Ω	1 M Ω	Filters off or antialias filter on 10 MHz, -1 dBFS input signal Includes the 2 nd through the 5 th harmonics
	0.2	-74 dBc	-68 dBc	
	0.4	-74 dBc	-68 dBc	
	1	-72 dBc	-68 dBc	
	2	-72 dBc	-67 dBc	
	4	-63 dBc	-66 dBc	
	10	-63 dBc	-58 dBc	
	20 (1 M Ω only)	—	-58 dBc	

Specification	Value				Comments	
Intermodulation Distortion, Typical	0.2 V _{pk-pk} to 2.0 V _{pk-pk} Ranges on 50 Ω Input				Filters off or antialias filter on Two tones at 10.2 MHz and 11.2 MHz Each tone is -7 dBFS	
	-75 dBc					
Signal-to-Noise Ratio (SNR), Typical	Range (V _{pk-pk})	50 Ω		1 MΩ		Excludes harmonics 10 MHz, -1 dBFS input signal Measured from DC to 100 MHz
		Filters Off	Antialias Filter On	Filters Off	Antialias Filter On	
	0.2	57 dB	56 dB	53 dB	55 dB	
	0.4	58 dB	57 dB	55 dB	57 dB	
	1	58 dB	58 dB	57 dB	57 dB	
	2	58 dB	58 dB	57 dB	57 dB	
	4	—	—	56 dB	58 dB	
Signal to Noise and Distortion (SINAD), Typical	Range (V _{pk-pk})	50 Ω		1 MΩ		Includes harmonics 10 MHz, -1 dBFS input signal Measured from DC to 100 MHz
		Filters Off	Antialias Filter On	Filters Off	Antialias Filter On	
	0.2	57 dB	56 dB	53 dB	55 dB	
	0.4	58 dB	57 dB	55 dB	57 dB	
	1	58 dB	58 dB	57 dB	57 dB	
	2	58 dB	58 dB	57 dB	57 dB	
	4	—	—	56 dB	57 dB	

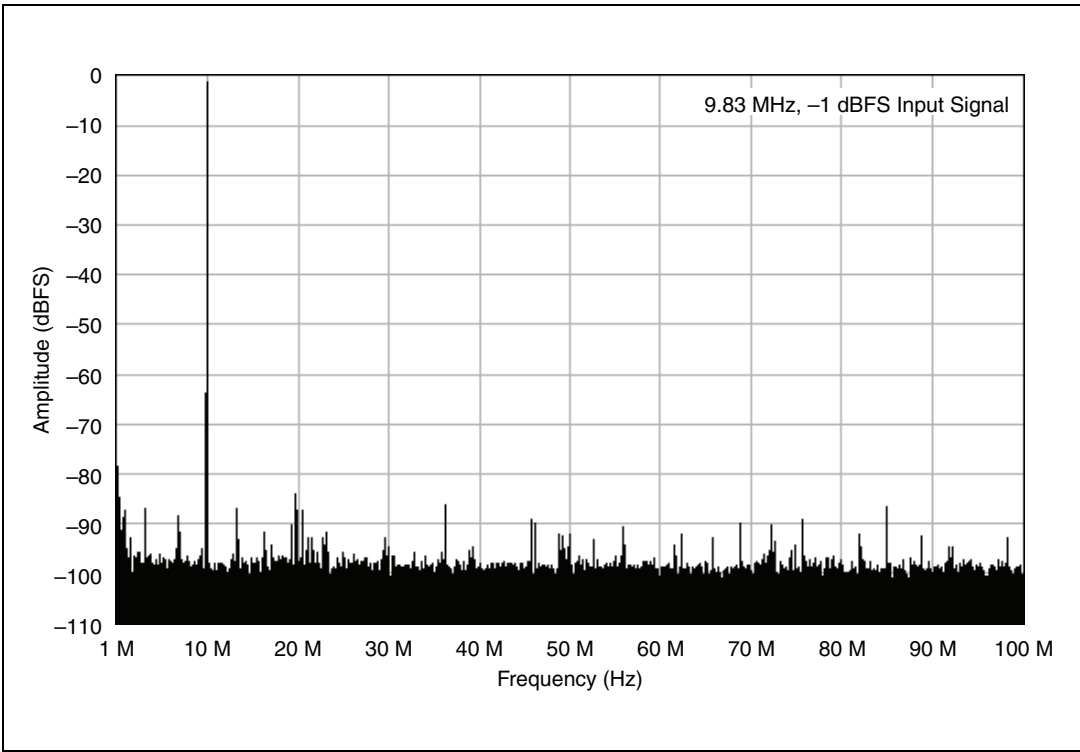

Figure 2. NI 5124 Dynamic Performance, 50 Ω , 1 V_{pk-pk} Range, 262,144 Point FFT (Typical)

Specification	Value			Comments
RMS Noise	Range (V_{pk-pk})	50 Ω	1 M Ω	Noise filter on 50 Ω terminator connected to input
	0.2	NI PXI-5124: 94 μV_{rms} (0.047% FS) NI PCI-5124: 106 μV_{rms} (0.053% FS)	NI PXI-5124: 104 μV_{rms} (0.052% FS) NI PCI-5124: 116 μV_{rms} (0.058% FS)	
	0.4	188 μV_{rms} (0.047% FS)	192 μV_{rms} (0.048% FS)	
	1	470 μV_{rms} (0.047% FS)	480 μV_{rms} (0.048% FS)	
	2	940 μV_{rms} (0.047% FS)	960 μV_{rms} (0.048% FS)	
	4	1.88 mV _{rms} (0.047% FS)	1.92 mV _{rms} (0.048% FS)	
	10	4.7 mV _{rms} (0.047% FS)	4.8 mV _{rms} (0.048% FS)	
	20 (1 M Ω only)	—	9.4 mV _{rms} (0.047% FS)	

Specification	Value			Comments
RMS Noise	Range (V_{pk-pk})	50 Ω	1 M Ω	Antialias filter on 50 Ω terminator connected to input
	0.2	NI PXI-5124: 112 μV_{rms} (0.056% FS) NI PCI-5124: 126 μV_{rms} (0.063% FS)	NI PXI-5124: 130 μV_{rms} (0.065% FS) NI PCI-5124: 146 μV_{rms} (0.073% FS)	
	0.4	200 μV_{rms} (0.05% FS)	216 μV_{rms} (0.054% FS)	
	1	500 μV_{rms} (0.05% FS)	510 μV_{rms} (0.051% FS)	
	2	1.0 mV _{rms} (0.05% FS)	1.02 mV _{rms} (0.051% FS)	
	4	2.04 mV _{rms} (0.051% FS)	2.16 mV _{rms} (0.054% FS)	
	10	5.1 mV _{rms} (0.051% FS)	5.2 mV _{rms} (0.052% FS)	
	20 (1 M Ω only)	N/A	10.2 mV _{rms} (0.051% FS)	

Specification	Value			Comments
RMS Noise	Range (V_{pk-pk})	50 Ω	1 M Ω	Filters off 50 Ω terminator connected to input
	0.2	NI PXI-5124: 114 μV_{rms} (0.057% FS) NI PCI-5124: 128 μV_{rms} (0.064% FS)	NI PXI-5124: 164 μV_{rms} (0.082% FS) NI PCI-5124: 184 μV_{rms} (0.092% FS)	
	0.4	204 μV_{rms} (0.051% FS)	264 μV_{rms} (0.066% FS)	
	1	510 μV_{rms} (0.051% FS)	550 μV_{rms} (0.055% FS)	
	2	1.02 mV _{rms} (0.051% FS)	1.08 mV _{rms} (0.054% FS)	
	4	2.08 mV _{rms} (0.052% FS)	2.6 mV _{rms} (0.065% FS)	
	10	5.2 mV _{rms} (0.052% FS)	5.5 mV _{rms} (0.055% FS)	
	20	—	10.6 mV _{rms} (0.053% FS)	

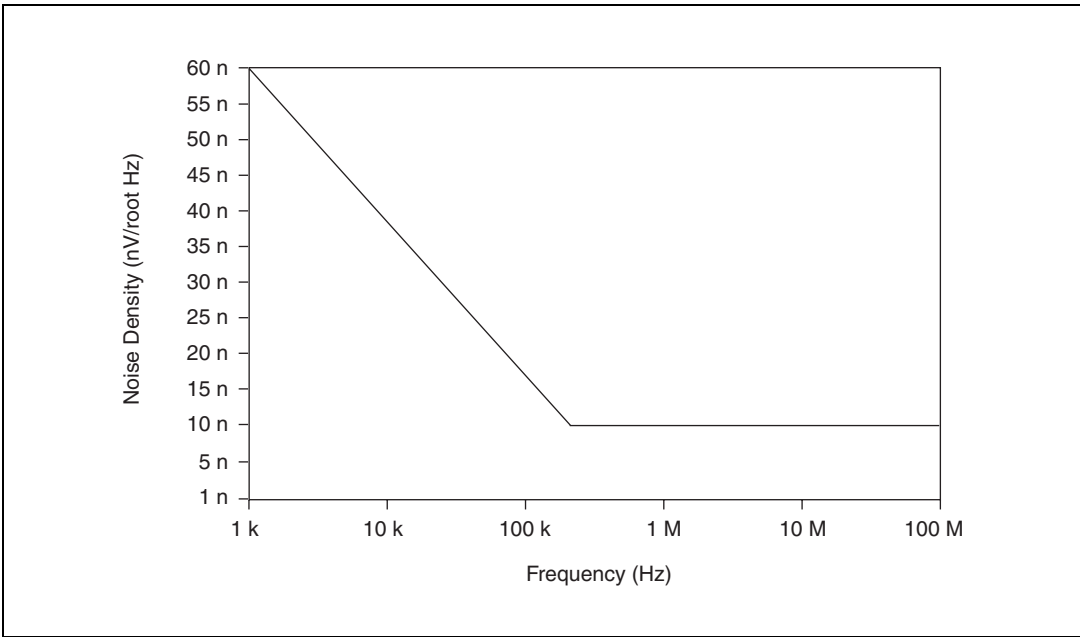

Figure 3. Representation of NI 5124 Spectral Noise Density on 0.2 V Range, Noise Filter Enabled, 1 M Ω Input Impedance

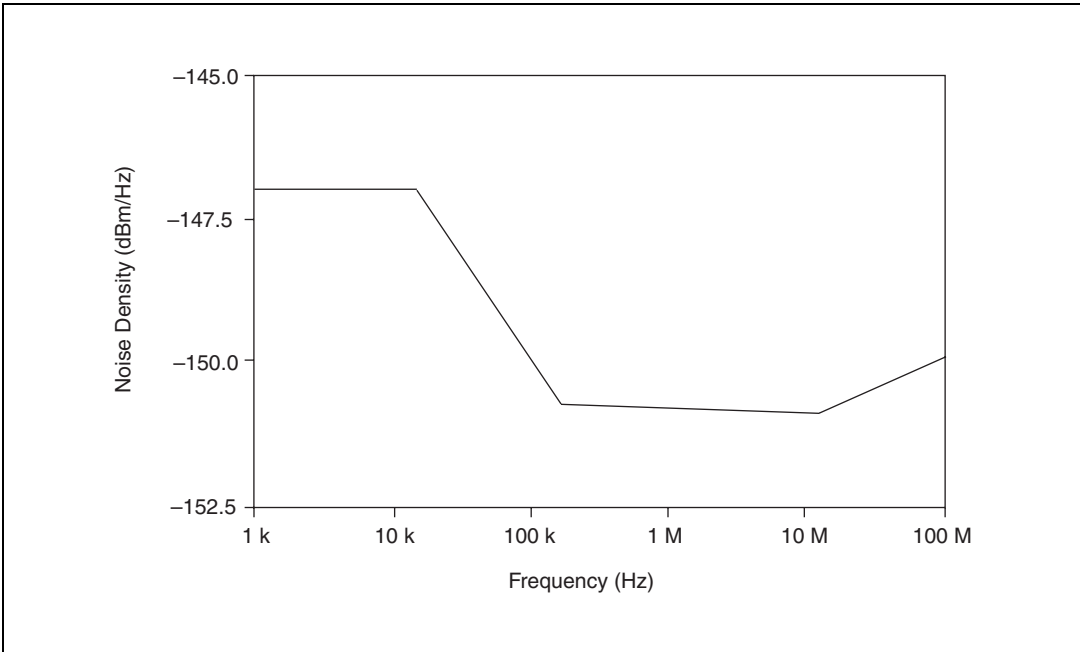

Figure 4. Representation of NI 5124 Spectral Noise Density on 0.2 V Range, Full Bandwidth, 50 Ω Input Impedance

Horizontal

Sample Clock

Specification	Value		Comments
Sources	NI PXI-5124	NI PCI-5124	* Internal Sample Clock is locked to the Reference Clock or derived from the onboard VCXO
	Internal, Onboard Clock (internal VCXO)*	Internal, Onboard Clock (internal VCXO)*	
	External, CLK IN (front panel SMB connector)	External, CLK IN (front panel SMB connector)	
	External, PXI Star Trigger (backplane connector)		
Onboard Clock (Internal VCXO)			
Sample Rate Range	Real-Time Sampling (Single Shot)	Random Interleaved Sampling (RIS)	* Divide by n decimation used for all rates less than 200 MS/s For more information about Sample Clock and decimation, refer to the <i>NI High-Speed Digitizers Help</i> .
	3.052 kS/s to 200 MS/s*	400 MS/s to 4 GS/s in multiples of 200 MS/s	
Phase Noise Density, Typical	<-100 dBc/Hz at 100 Hz <-120 dBc/Hz at 1 kHz <-130 dBc/Hz at 10 kHz		10 MHz input signal

Specification	Value		Comments
Sample Clock Jitter, Typical	≤ 1 ps rms (100 Hz to 100 kHz) ≤ 2 ps rms (100 Hz to 1 MHz)		Includes the effects of the converter aperture uncertainty and the clock circuitry jitter Excludes trigger jitter
Timebase Frequency	200 MHz		—
Timebase Accuracy	Not Phase-Locked to Reference Clock	Phase-Locked to Reference Clock	—
	± 25 ppm	Equal to the Reference Clock accuracy	
Sample Clock Delay Range	± 1 Sample Clock period		—
Sample Clock Delay/Adjustment Resolution	≤ 5 ps		—

Specification	Value		Comments
External Sample Clock			
Sources	NI PXI-5124	NI PCI-5124	—
	CLK IN (front panel SMB connector) PXI Star Trigger (backplane connector)	CLK IN (front panel SMB connector)	
Frequency Range	50 MHz to 210 MHz (CLK IN) 50 MHz to 80 MHz (PXI Star Trigger)		Divide by n decimation available where $1 \leq n \leq 65,535$ For more information about Sample Clock and decimation, refer to the <i>NI High-Speed Digitizers Help</i> .
Duty Cycle Tolerance	45% to 55%		—
Exported Reference Clock Destinations	NI PXI-5124	NI PCI-5124	—
	CLK OUT (front panel SMB connector) PFI<0..1> (front panel 9-pin mini-circular DIN connector) PXI_Trig<0..7> (backplane connector)	CLK OUT (front panel SMB connector) PFI<0..1> (front panel 9-pin mini-circular DIN connector) RTSI<0..7>	

Specification	Value		Comments
Sample Clock Exporting			
Exported Sample Clock Destinations	Destination	Maximum Frequency	* Decimated Sample Clock only
	CLK OUT (front panel SMB connector)	210 MHz	
	PXI_Trig<0..6> (backplane connector)*	20 MHz	
	PFI<0..1> (front panel 9-pin mini-circular DIN connector)*	25 MHz	
	RTSI<0..6>*	20 MHz	

Phase-Locked Loop (PLL) Reference Clock

Specification	Value		Comments
Sources	NI PXI-5124	NI PCI-5124	—
	PXI_CLK10 (backplane connector) CLK IN (front panel SMB connector)	RTSI 7 CLK IN (front panel SMB connector)	
Frequency Range	1 MHz to 20 MHz in 1 MHz increments. Default of 10 MHz. The PLL Reference Clock frequency must be accurate to ± 50 ppm.		—
Duty Cycle Tolerance	45% to 55%		—
Exported Reference Clock Destinations	NI PXI-5124	NI PCI-5124	—
	CLK OUT (front panel SMB connector) PFI<0..1> (front panel 9-pin mini-circular DIN connector)	CLK OUT (front panel SMB connector) PFI<0..1> (front panel 9-pin mini-circular DIN connector)	
	PXI_Trig<0..6> (backplane connector)	RTSI<0..7>	

CLK IN (Sample Clock and Reference Clock Input, Front Panel Connector)

Specification	Value	Comments
Input Voltage Range	Sine wave: $0.65 V_{pk-pk}$ to $2.8 V_{pk-pk}$ (0 dBm to 13 dBm) Square wave: $0.2 V_{pk-pk}$ to $2.8 V_{pk-pk}$	—
Maximum Input Overload	$7 V_{rms}$ with $ Peaks \leq 10 V$	—
Impedance	50Ω	—
Coupling	AC	—

CLK OUT (Sample Clock and Reference Clock Output, Front Panel Connector)

Specification	Value	Comments
Output Impedance	50Ω	—
Logic Type	3.3 V CMOS	—
Maximum Drive Current	± 48 mA	—

Trigger

Reference (Stop) Trigger

Specification	Value		Comments
Trigger Types and Sources	Types	Sources	Refer to the following sections and the <i>NI High-Speed Digitizers Help</i> for more information about what sources are available for each trigger type.
	Edge, Window, Hysteresis, Video, Digital, Immediate, and Software	CH 0, CH 1, TRIG, PXI_Trig<0..6>, PFI<0..1>, PXI Star Trigger, Software, and RTSI<0..6>	

Specification	Value			Comments
Time Resolution	TDC	Onboard Clock	External Clock	TDC = Time to Digital Conversion Circuit
	On	50 ps	N/A	
	Off	5 ns	External Clock Period	
Rearm Time	TDC		Rearm Time	Holdoff set to 0
	On		10 μ s	
	Off		2 μ s	
Holdoff	TDC	Onboard Clock	External Clock	—
	On	10 μ s to 85.899 s	N/A	
	Off	2 μ s to 85.899 s	$200 \times (\text{External Clock Period})$ to $(2^{32} - 1) \times (\text{External Clock Period})$	
Analog Trigger (Edge, Window, and Hysteresis Trigger Types)				
Sources	CH 0 (front panel BNC connector) CH 1 (front panel BNC connector) TRIG (front panel BNC connector)			—
Trigger Level Range	CH 0, CH 1		TRIG (External Trigger)	—
	100% FS		± 5 V	
Trigger Level Resolution	10 bits (1 in 1,024)			—
Edge Trigger Sensitivity	CH 0, CH 1		TRIG (External Trigger)	—
	3.5% FS up to 50 MHz, increasing to 10% FS at 150 MHz		0.25 $V_{\text{pk-pk}}$ up to 100 MHz, increasing to 1 $V_{\text{pk-pk}}$ at 200 MHz	
Level Accuracy, Typical	CH 0, CH 1		TRIG (External Trigger)	—
	$\pm 4.7\%$ FS up to 10 MHz		± 0.35 V up to 10 MHz	
Trigger Jitter	≤ 80 ps rms			Within ± 5 $^{\circ}$ C of self-calibration temperature

Specification	Value		Comments
Trigger Filters	Low-Frequency (LF) Reject	High-Frequency (HF) Reject	—
	50 kHz	50 kHz	
Digital Trigger (Digital Trigger Type)			
Sources	NI PXI-5124	NI PCI-5124	—
	PXI_Trig<0..6> (backplane connector) PFI<0..1> (front panel SMB connector) PXI Star Trigger (backplane connector)	RTSI<0..6> PFI<0..1> (front panel SMB connector)	
Video Trigger (Video Trigger Type)			
Sources	CH 0 (front panel BNC connector) CH 1 (front panel BNC connector) TRIG (front panel BNC connector)		—
Types	Specific Line Any Line Specific Field		—
Standard	Negative sync of NTSC, PAL, or SECAM signal		—

TRIG (External Trigger, Front Panel Connector)

Specification	Value	Comments
Connector	BNC	—
Impedance	1 M Ω in parallel with 22 pF	—
Coupling	AC, DC	—
AC-Coupling Cutoff (-3 dB)	12 Hz	—
Input Voltage Range	± 5 V	—
Maximum Input Overload	Peaks ≤ 42 V	—

PFI 0 and PFI 1 (Programmable Function Interface, AUX Front Panel Connector)

Specification	Value	Comments
Connector	9-pin mini-circular DIN	—
Direction	Bi-directional	—
As an Input (Trigger)		
Destinations	Start Trigger (Acquisition Arm) Reference (Stop) Trigger Arm Reference Trigger Advance Trigger	—
Input Impedance	150 k Ω	—
V _{IH}	2.0 V	—
V _{IL}	0.8 V	—
Maximum Input Overload	-0.5 V, 5.5 V	—
Maximum Frequency	25 MHz	—
As an Output (Event)		
Sources	Start Trigger (Acquisition Arm) Reference (Stop) Trigger End of Record Done (End of Acquisition) Probe Compensation (1 kHz, 50% duty cycle square wave, PFI 1 only)	—
Output Impedance	50 Ω	—
Logic Type	3.3 V CMOS	—
Maximum Drive Current	\pm 24 mA	—
Maximum Frequency	25 MHz	—

TClk Specifications

National Instruments TClk synchronization method and the NI-TClk driver are used to align the sample clocks on any number of SMC-based modules in a chassis. For more information about TClk synchronization, refer to the *NI-TClk Synchronization Help*, which is located within the *NI High-Speed Digitizers Help*.

- Specifications are valid for any number of modules installed in one NI PXI-1042 chassis.
- All parameters set to identical values for each SMC-based module.
- Sample Clock set to 200 MS/s and all filters are disabled.
- For other configurations, including multichassis systems, contact NI Technical Support at ni.com/support.



Note Although you can use NI-TClk to synchronize nonidentical modules, these specifications apply only to synchronizing identical modules.

Specification	Value	Comments
Intermodule SMC Synchronization Using NI-TClk for Identical Modules (Typical)		
Skew	500 ps	Caused by clock and analog path delay differences No manual adjustment performed
Skew After Manual Adjustment	<10 ps	For information about manual adjustment, refer to the <i>Synchronization Repeatability Optimization</i> topic in the <i>NI-TClk Synchronization Help</i> . For additional help with the adjustment process, contact NI Technical Support at ni.com/support .
Sample Clock Delay/Adjustment Resolution	≤5 ps	—

Waveform Specifications

Specification	Value		Comments
Onboard Memory Size	8 MB per channel standard (4 megasamples per channel)		* NI PXI-5124 only
	32 MB per channel option (16 megasamples per channel)		
	256 MB per channel option (128 megasamples per channel)		
	512 MB per channel option (256 megasamples per channel)*		
Minimum Record Length	1 Sample		—
Number of Pretrigger Samples	Zero up to full Record Length		Single-record mode and multiple-record mode
Number of Posttrigger Samples	Zero up to full Record Length		Single-record mode and multiple-record mode
Maximum Number of Records in Onboard Memory	8 MB/channel	21,845	* NI PXI-5124 only † It is possible to exceed these numbers if you fetch records while acquiring data. For more information, refer to the <i>NI High-Speed Digitizers Help</i> .
	32 MB/channel	87,381	
	256 MB/channel	100,000†	
	512 MB/channel*	100,000†	
Allocated Onboard Memory per Record	$(Record\ Length \times 2\ bytes/S) + 200\ bytes$, rounded up to next multiple of 128 bytes or 384 bytes, whichever is greater		—

Calibration

Specification	Value	Comments
Self-Calibration	Self-calibration is done on software command. The calibration corrects for gain, offset, frequency response, triggering, and timing adjustment errors for all input ranges.	—
External Calibration (Factory Calibration)	The external calibration calibrates the VCXO and the voltage reference. Appropriate constants are stored in nonvolatile memory.	—
Interval for External Calibration	2 years	—
Warm-Up Time	15 minutes	—

Power

Specification	Typical Value		Comments
	NI PXI-5124	NI PCI-5124	
+3.3 VDC	1.3 A	1.3 A	—
+5 VDC	1.7 A	2.7 A	
+12 VDC	130 mA	130 mA	
-12 VDC	270 mA	0 A	
Total Power	17.6 W	19.4 W	

Software

Specification	Value	Comments
Driver Software	NI-SCOPE 2.7 or later NI-SCOPE is an IVI-compliant driver that allows you to configure, control, and calibrate the NI 5124. NI-SCOPE provides application programming interfaces for many development environments.	—
Application Software	NI-SCOPE provides programming interfaces, documentation, and examples for the following application development environments: <ul style="list-style-type: none">• LabVIEW• LabWindows™/CVI™• Measurement Studio• Microsoft Visual C/C++• Microsoft Visual Basic	—
Interactive Soft Front Panel and Configuration	The Scope Soft Front Panel supports interactive control of the NI 5124. The Scope Soft Front Panel is included on the NI-SCOPE CD. National Instruments Measurement & Automation Explorer (MAX) also provides interactive configuration and test tools for the NI 5124. MAX is included on the NI-SCOPE CD.	—

Environment

NI PXI-5124



Note To ensure that the NI PXI-5124 cools effectively, follow the guidelines in the *Maintain Forced Air Cooling Note to Users* included in the NI PXI-5124 kit. The NI PXI-5124 is intended for indoor use only.

Specification	Value	Comments
Operating Temperature	0 °C to +55 °C in all NI PXI chassis except the following: 0 °C to +45 °C when installed in an NI PXI-1000/B or PXI-101x chassis Meets IEC-60068-2-1 and IEC-60068-2-2	—
Storage Temperature	–40 °C to +71 °C Meets IEC-60068-2-1 and IEC-60068-2-2	—
Operating Relative Humidity	10% to 90%, noncondensing Meets IEC-60068-2-56	—
Storage Relative Humidity	5% to 95%, noncondensing Meets IEC-60068-2-56	—
Operating Shock	30 g, half-sine, 11 ms pulse Meets IEC-60068-2-27 Test profile developed in accordance with MIL-PRF-28800F	—
Storage Shock	50 g, half-sine, 11 ms pulse Meets IEC-60068-2-27 Test profile developed in accordance with MIL-PRF-28800F	—
Operating Vibration	5 Hz to 500 Hz, 0.31 g _{rms} Meets IEC-60068-2-64	—
Storage Vibration	5 Hz to 500 Hz, 2.46 g _{rms} Meets IEC-60068-2-64 Test profile exceeds requirements of MIL-PRF-28800F, Class B	—
Altitude	2,000 m maximum (at 25 °C ambient temperature)	—
Pollution Degree	2	—

NI PCI-5124



Note To ensure that the NI PCI-5124 cools effectively, make sure that the chassis in which it is used has active cooling that provides at least some airflow across the PCI card cage. To maximize airflow and extend the life of the device, leave any adjacent PCI slots empty. Refer to the *Maintain Forced Air Cooling Note to Users* included in the NI PCI-5124 kit for important cooling information. The NI PCI-5124 is intended for indoor use only.

Specification	Value	Comments
Operating Temperature	0 °C to +45 °C Meets IEC-60068-2-1 and IEC-60068-2-2	—
Storage Temperature	−40 °C to +71 °C Meets IEC-60068-2-1 and IEC-60068-2-2	—
Operating Relative Humidity	10% to 90%, noncondensing Meets IEC-60068-2-56	—
Storage Relative Humidity	5% to 95%, noncondensing Meets IEC-60068-2-56	—
Storage Shock	50 g, half-sine, 11 ms pulse Meets IEC-60068-2-27 Test profile developed in accordance with MIL-PRF-28800F	—
Storage Vibration	5 Hz to 500 Hz, 2.46 g _{rms} Meets IEC-60068-2-64 Test profile exceeds requirements of MIL-PRF-28800F, Class B	—
Altitude	2,000 m maximum (at 25 °C ambient temperature)	—
Pollution Degree	2	—

Safety, Electromagnetic Compatibility, and CE Compliance

Safety

This product is designed to meet the requirements of the following standards of safety for electrical equipment for measurement, control, and laboratory use:

- IEC 61010-1, EN 61010-1
- UL 61010-1, CSA 61010-1



Note For UL and other safety certifications, refer to the product label or visit ni.com/certification, search by model number or product line, and click the appropriate link in the Certification column.

Electromagnetic Compatibility

This product is designed to meet the requirements of the following standards of EMC for electrical equipment for measurement, control, and laboratory use:

- EN 61326 EMC requirements; Minimum Immunity
- EN 55011 Emissions; Group 1, Class A
- CE, C-Tick, ICES, and FCC Part 15 Emissions; Class A



Note For EMC compliance, operate this device with RG223/U or equivalent shielded cable. Operate according to product documentation

CE Compliance

This product meets the essential requirements of applicable European Directives, as amended for CE marking, as follows:

- 2006/95/EC; Low-Voltage Directive (safety)
- 2004/108/EC; Electromagnetic Compatibility Directive (EMC)



Note Refer to the Declaration of Conformity (DoC) for this product for any additional regulatory compliance information. To obtain the DoC for this product, visit ni.com/certification, search by model number or product line, and click the appropriate link in the Certification column.

Environmental Management

National Instruments is committed to designing and manufacturing products in an environmentally responsible manner. NI recognizes that eliminating certain hazardous substances from our products is beneficial not only to the environment but also to NI customers.

For additional environmental information, refer to the *NI and the Environment* Web page at ni.com/environment. This page contains the environmental regulations and directives with which NI complies, as well as any other environmental information not included in this document.

Waste Electrical and Electronic Equipment (WEEE)



EU Customers At the end of their life cycle, all products *must* be sent to a WEEE recycling center. For more information about WEEE recycling centers and National Instruments WEEE initiatives, visit ni.com/environment/weee.htm.

电子信息产品污染控制管理办法（中国 RoHS）



中国客户 National Instruments 符合中国电子信息产品中限制使用某些有害物质指令 (RoHS)。关于 National Instruments 中国 RoHS 合规性信息，请登录 ni.com/environment/rohs_china。(For information about China RoHS compliance, go to ni.com/environment/rohs_china.)

Physical

Front Panel Connectors

Label	Function	Connector Type
CH 0	Analog Input	BNC female
CH 1	Analog Input	BNC female
TRIG	External Trigger	BNC female
CLK IN	Sample Clock Input and Reference Clock Input	SMB jack
CLK OUT	Sample Clock Output and Reference Clock Output	SMB jack
AUX I/O	PFI 0, PFI 1	9-pin mini-circular DIN

NI PXI-5124 Front Panel Indicators		
Label	Function	For more information, refer to the <i>NI High-Speed Digitizers Help</i> .
ACCESS	The ACCESS LED indicates the status of the PCI bus and the interface from the NI PXI-5124 to the controller.	
ACTIVE	The ACTIVE LED indicates the status of the onboard acquisition hardware of the NI PXI-5124.	

Dimensions and Weight

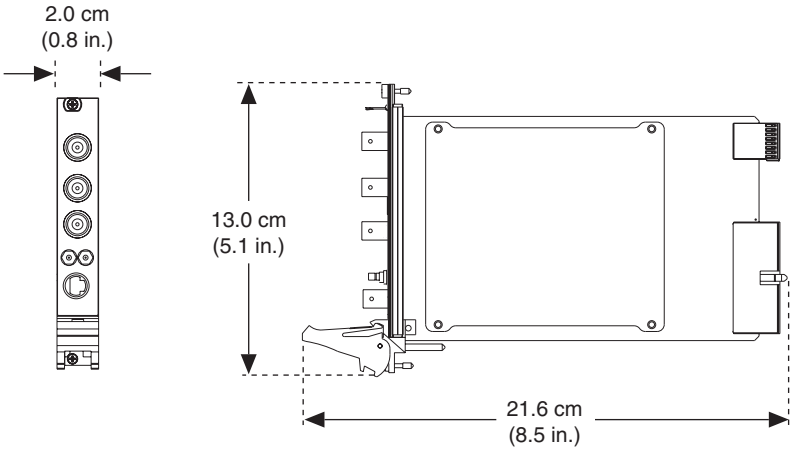
NI PXI-5124	
Dimensions	<p>3U, One slot, PXI/cPCI Module 21.6 × 2.0 × 13.0 cm (8.5 × 0.8 × 5.1 in.)</p> 
Weight	383 g (13.5 oz)

NI PCI-5124

Dimensions

35.5 × 2.0 × 11.3 cm
(14.0 × 0.8 × 4.4 in.)

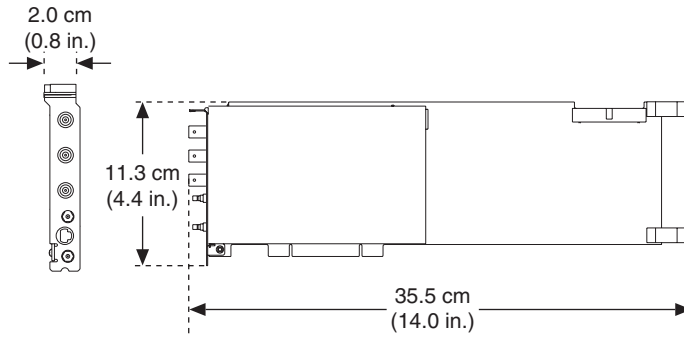

Weight

455 g (16 oz)

Where to Go for Support

The National Instruments Web site is your complete resource for technical support. At ni.com/support you have access to everything from troubleshooting and application development self-help resources to email and phone assistance from NI Application Engineers.

A Declaration of Conformity (DoC) is our claim of compliance with the Council of the European Communities using the manufacturer's declaration of conformity. This system affords the user protection for electronic compatibility (EMC) and product safety. You can obtain the DoC for your product by visiting ni.com/certification. If your product supports calibration, you can obtain the calibration certificate for your product at ni.com/calibration.

National Instruments corporate headquarters is located at 11500 North Mopac Expressway, Austin, Texas, 78759-3504. National Instruments also has offices located around the world to help address your support needs. For telephone support in the United States, create your service request at ni.com/support and follow the calling instructions or dial 512 795 8248. For telephone support outside the United States, contact your local branch office:

Australia 1800 300 800, Austria 43 662 457990-0,
Belgium 32 (0) 2 757 0020, Brazil 55 11 3262 3599,
Canada 800 433 3488, China 86 21 5050 9800,
Czech Republic 420 224 235 774, Denmark 45 45 76 26 00,
Finland 358 (0) 9 725 72511, France 01 57 66 24 24,
Germany 49 89 7413130, India 91 80 41190000, Israel 972 3 6393737,
Italy 39 02 413091, Japan 81 3 5472 2970, Korea 82 02 3451 3400,
Lebanon 961 (0) 1 33 28 28, Malaysia 1800 887710,
Mexico 01 800 010 0793, Netherlands 31 (0) 348 433 466,
New Zealand 0800 553 322, Norway 47 (0) 66 90 76 60,
Poland 48 22 3390150, Portugal 351 210 311 210, Russia 7 495 783 6851,
Singapore 1800 226 5886, Slovenia 386 3 425 42 00,
South Africa 27 0 11 805 8197, Spain 34 91 640 0085,
Sweden 46 (0) 8 587 895 00, Switzerland 41 56 2005151,
Taiwan 886 02 2377 2222, Thailand 662 278 6777,
Turkey 90 212 279 3031, United Kingdom 44 (0) 1635 523545

National Instruments, NI, ni.com, and LabVIEW are trademarks of National Instruments Corporation. Refer to the *Terms of Use* section on ni.com/legal for more information about National Instruments trademarks. Other product and company names mentioned herein are trademarks or trade names of their respective companies. For patents covering National Instruments products, refer to the appropriate location: **Help»Patents** in your software, the `patents.txt` file on your CD, or ni.com/patents.